

CDD10

Compact Coaxial Differential Dispersion System

Features

- Compact, CDD™ passive two-way system
- Coaxial Differential Dispersion™ technology
- Elegant UPM Formi composite enclosure
- User-rotatable coaxial drive unit
- Vertical and horizontal mounting options
- Screw-free perforated steel grille
- 8Ω nominal impedance
- Discreet mounting accessories
- Integral inserts for eyebolt suspension
- Black or white standard colour options

Applications

- Live music clubs and bars
- Nightclubs
- Bars and restaurants
- Museums and AV spaces
- Convention centres
- Hotels
- Retail outlets
- Leisure centres
- Houses of Worship

The CDD10 is a very compact two-way passive loudspeaker system which utilises a 10" (250mm) LF/1" (25mm) exit HF Coaxial Differential Dispersion driver. It is uniquely placed to meet the foreground requirements of music bars and clubs, as well as the varied architectural applications that require upfront sound levels from a very compact enclosure. Use with a SX118 or SX218 subwoofer will enable the CDD10 to operate as small dancefloor system that is remarkably powerful for its size.

The Coaxial Differential Dispersion technology employed in the CDD10 delivers more consistent audience coverage than systems with fixed X° x Y° coverage patterns — projecting relatively more output to the rear of the audience, while having wide horizontal coverage close-up. Its innovative CDD driver achieves 'point source' summation of the LF and HF sections — eliminating off-axis variations in frequency response associated with non-coaxial designs. Improving on conventional coaxial designs, which can suffer from high-frequency beaming, the driver features a static waveguide that merges seamlessly with the unique cone shape — maintaining the dispersion pattern out to very high frequencies.



The visually-distinctive composite enclosure can be used in either horizontal (landscape) or vertical (portrait) orientation, with rotation of the driver easily accomplished by removing the screw-free, protective grille. The curved shape of the CDD10 allows it to be surface-mounted close to a wall via an optional wall bracket or suspended from a ceiling by eyebolts or a horizontal yoke option.

Finished in black (RAL9005) or white (RAL9016) as standard, the CDD10 can be supplied in any RAL colour to order.

A full-range, passive two-way system, the CDD10 should be used with a compatible controller with appropriate limiter settings to provide system protection.

When used with the DX4.0 controller or an iKON amplifier, there are now enhanced DSP and FIR based pre-sets to deliver the absolute maximum performance and fidelity while limiter settings protect the integrity of the system.

CDD10

Compact Coaxial Differential Dispersion System

Technical Specifications

Acoustical

TYPE	Compact, Coaxial Differential Dispersion passive two-way system
FREQUENCY RESPONSE (5)	65Hz-20kHz \pm 3dB, -10dB @ 55Hz
DRIVER	LF: 10" (250mm)/2.5" (63.5mm) voice coil, long excursion, shared ferrite motor system with HF HF: 1" (25mm) exit/1.4" (38mm) voice coil, polyimide dome compression driver
RATED POWER (2)	250W AES, 1000W peak
RECOMMENDED AMPLIFIER	iK81, VIA2502, VIA2004
SENSITIVITY (8)	96dB
MAXIMUM SPL (9)	120dB continuous, 126dB peak
NOMINAL IMPEDANCE	8 ohms
DISPERSION (-6dB)	110°-75° horizontal, 60° vertical (user-rotatable)
CROSSOVER	2kHz passive
ENCLOSURE	28 litre, composite material
FINISH	Black or white textured paint
PROTECTIVE GRILLE	Black or white perforated steel with scrim cloth backing
CONNECTORS	Low profile 20A push-lock
PIN CONNECTIONS	Left to right: Input+, Input -, Link -, Link+
FITTINGS	6 x M8 inserts for wall bracket 10 x M8 fly points
DIMENSIONS	(W) 323mm x (H) 513mm x (D) 310mm (W) 12.7ins x (H) 20.2ins x (D) 12.2ins
WEIGHT	15.3kg (33.7lbs)
ACCESSORIES	CDDWB10/12B wall bracket black CDDWB10/12W wall bracket white CDDY10B yoke assembly black CDDY10W yoke assembly white

Notes

- (1) Measured on-axis in half (2pi) space at 2 metres, then referred to 1 metre.
- (2) AES Standard ANSI S4.26-1984.
- (3) Measured in half (2pi) space at 2 metres with 1 watt input, using band limited pink noise, then referred to 1 metre.
- (4) Measured in half (2pi) space at 2 metres using band limited pink noise, then referred to 1 metre.
- (5) Measured on-axis in open (4pi) space at 2 metres, then referred to 1 metre.
- (6) Measured in open (4pi) space at 2 metres with 1 watt input, using band limited pink noise, then referred to 1 metre.
- (7) Measured in open (4pi) space at 2 metres using band limited pink noise, then referred to 1 metre.
- (8) Measured in open (4pi) space at 2 metres with 2.83V input, using band limited pink noise, then referred to 1 metre.
- (9) Calculated at 1 metre.
- (10) Measured in half (2pi) space at 2 metres with 2.83V input, using band limited pink noise, then referred to 1 metre.

Trade Descriptions Act

Due to Martin Audio's policy of continuing improvement, we reserve the right to alter these specifications without prior notice. Martin Audio is committed to refining state of the art sound reinforcement, combining in-depth product and field applications research with advanced manufacturing techniques. Every Martin Audio product is built to the highest manufacturing standards and rigorously tested to ensure that it meets the performance criteria specified in the design.

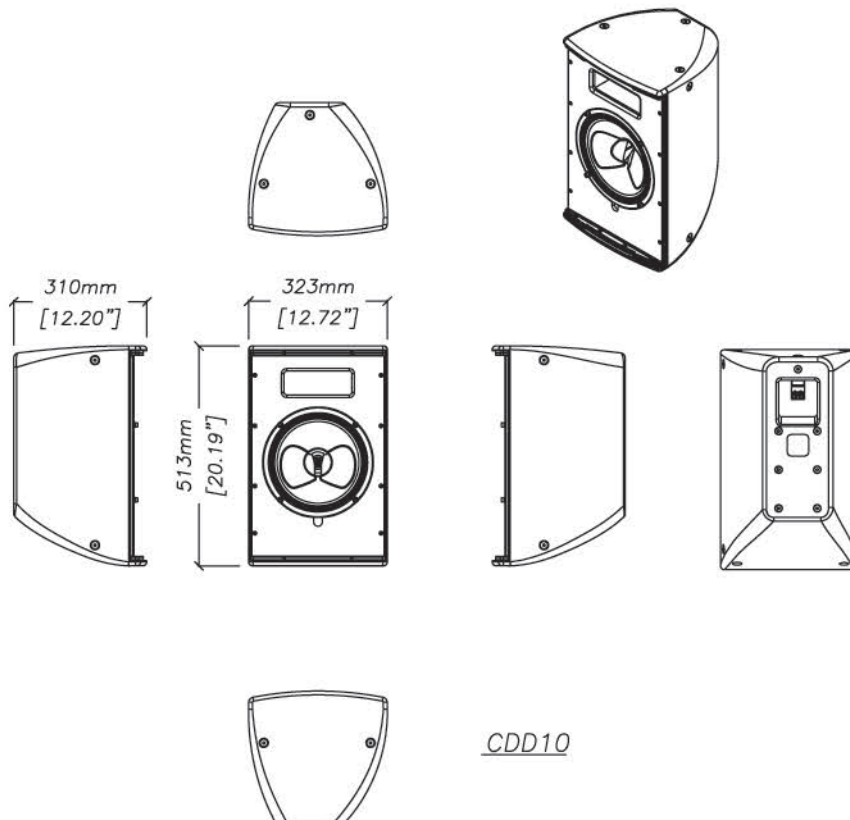

CDD10