

# CDD6

## Ultra-Compact Coaxial Differential Dispersion System

### Features

- Ultra-compact, CDD™ passive two-way system
- Coaxial Differential Dispersion™ technology
- Elegant UPM Formi composite enclosure
- User-rotatable coaxial drive unit
- Vertical and horizontal mounting options
- Screw-free perforated steel grille
- 8Ω nominal impedance
- Discreet mounting accessories
- Black or white standard colour options

### Applications

- Bars and restaurants
- Museums and AV spaces
- Convention centres
- Hotels
- Retail outlets
- Leisure centres
- Houses of Worship



The ultra-compact CDD6 is a two-way passive loudspeaker system designed to fulfil the requirement for full-frequency dynamic performance from a very small enclosure. Featuring a 6.5" (165mm) LF/1" (25mm) HF Coaxial Differential Dispersion driver, its extremely small size and sleek lines make it ideal for visibly-unobtrusive applications. It can also be used as a fill system in conjunction with larger CDD Series models and, with the addition of an SX subwoofer, can reproduce surprisingly high levels of music program.

The Coaxial Differential Dispersion technology employed in the CDD6 delivers more consistent audience coverage than systems with fixed X° x Y° coverage patterns — projecting relatively more output to the rear of the audience, while having wide horizontal coverage close-up. Its innovative CDD driver achieves 'point source' summation of the LF and HF sections — eliminating off-axis variations in frequency response associated with non-coaxial designs. Improving on conventional coaxial designs, which can suffer from high-frequency beaming, the driver features a static waveguide that merges seamlessly with the unique cone shape — maintaining the dispersion pattern out to very high frequencies.

The visually-distinctive enclosure can be used in either horizontal (landscape) or vertical (portrait) orientation, with rotation of the driver easily accomplished by removing the screw-free, protective grille. The curved shape of the enclosure allows it to be surface-mounted close to a wall or ceiling by means of optional wall and ceiling brackets.

Finished in black (RAL9005) or white (RAL9016) as standard, the CDD6 can be supplied in any RAL colour to order.

A full-range, passive two-way system, the CDD6 should be used with a compatible controller with appropriate limiter settings to provide system protection.

When used with the DX4.0 controller or an iKON amplifier, there are now enhanced DSP and FIR based pre-sets to deliver the absolute maximum performance and fidelity while limiter settings protect the integrity of the system.

# CDD6

## Ultra-Compact Coaxial Differential Dispersion System

### Technical Specifications

#### Acoustical

TYPE	Ultra-compact, Coaxial Differential Dispersion passive two-way system
FREQUENCY RESPONSE (5)	80Hz-20kHz $\pm$ 3dB, -10dB @ 70Hz
DRIVER	LF: 6.5" (165mm)/1.5" (38mm) voice coil, long excursion, ferrite motor system HF: 1" (25mm) voice coil, fabric dome with neodymium motor system
RATED POWER (2)	150W AES, 600W peak
RECOMMENDED AMPLIFIER	iK81, VIA2502, VIA2004
SENSITIVITY (8)	91dB
MAXIMUM SPL (9)	113dB continuous, 119dB peak
NOMINAL IMPEDANCE	8 ohms
DISPERSION (-6dB)	110°-80° horizontal, 80° vertical (user-rotatable)
CROSSOVER	2.5kHz passive
ENCLOSURE	9 litre, composite material
FINISH	Black or white textured paint
PROTECTIVE GRILLE	Black or white perforated steel with scrim cloth backing
CONNECTORS	Low profile 13A push-lock
PIN CONNECTIONS	Left to right: Input+, Input -, Link -, Link +
FITTINGS	4 x M6 inserts for wall/ceiling brackets
DIMENSIONS	(W) 210mm x (H) 325mm x (D) 210mm (W) 8.3ins x (H) 12.8ins x (D) 8.3ins
WEIGHT	5.69kg (12.54lbs)
ACCESSORIES	CDDWB6/8B wall bracket black CDDWB6/8W wall bracket white CDDCB6/8B ceiling bracket black CDDCB6/8W ceiling bracket white

#### Notes

- (1) Measured on-axis in half (2pi) space at 2 metres, then referred to 1 metre.
- (2) AES Standard ANSI S4.26-1984.
- (3) Measured in half (2pi) space at 2 metres with 1 watt input, using band limited pink noise, then referred to 1 metre.
- (4) Measured in half (2pi) space at 2 metres using band limited pink noise, then referred to 1 metre.
- (5) Measured on-axis in open (4pi) space at 2 metres, then referred to 1 metre.
- (6) Measured in open (4pi) space at 2 metres with 1 watt input, using band limited pink noise, then referred to 1 metre.
- (7) Measured in open (4pi) space at 2 metres using band limited pink noise, then referred to 1 metre.
- (8) Measured in open (4pi) space at 2 metres with 2.83V input, using band limited pink noise, then referred to 1 metre.
- (9) Calculated at 1 metre.
- (10) Measured in half (2pi) space at 2 metres with 2.83V input, using band limited pink noise, then referred to 1 metre.

#### Trade Descriptions Act

Due to Martin Audio's policy of continuing improvement, we reserve the right to alter these specifications without prior notice. Martin Audio is committed to refining state of the art sound reinforcement, combining in-depth product and field applications research with advanced manufacturing techniques. Every Martin Audio product is built to the highest manufacturing standards and rigorously tested to ensure that it meets the performance criteria specified in the design.

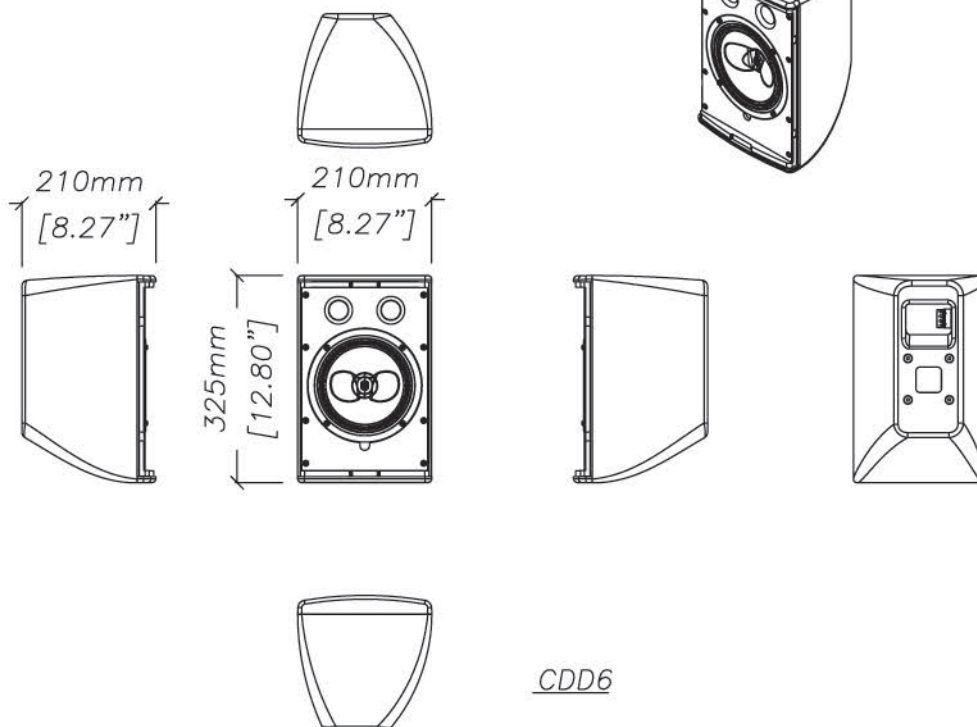

CDD6