

SX112

Ultra-Compact Subwoofer

Features

- Ultra-Compact, direct-radiator subwoofer
- 12" (300mm) driver with 3" (75mm) voice coil
- Water resistant cone
- Large ports for reduced air noise
- Perforated steel grille
- Black or white standard colour options
- Integrated flying points

Applications

- Live music clubs and bars
- Nightclubs
- Bars and restaurants
- Museums and AV spaces
- Convention centres
- Hotels
- Retail outlets
- Leisure centres
- Houses of Worship



The SX112 is an ultra-compact direct radiating sub-bass system designed to extend the bandwidth and increase the headroom of full-range loudspeaker models. It features a very efficient 12" (300mm) long-throw bass driver with a high power 3" (75mm) voice coil and generously-sized reflex ports for low noise, high power operation.

With a response of 48Hz-150Hz \pm 3dB, the ultra-compact size of the SX112 makes it an ideal partner for ADORN or CDD Series systems where space is at a premium or where the subwoofers need to be hidden. The enclosure is constructed from plywood

and has an impact-resistant finish, while the driver is protected by a rigid perforated steel grille, which is pre-curved to withstand physical damage.

Finished in black (RAL9005) or white (RAL9016) as standard with integrated flying points, the SX112 can be also be supplied in any RAL colour to order.

When used with full-range systems, crossover and EQ functions can either be performed by the DX0.5 or DX4.0 system controllers.

SX112

Ultra-Compact Subwoofer

Technical Specifications

Acoustical

TYPE	Ultra-Compact, single driver, direct radiating subwoofer
FREQUENCY RESPONSE (1)	48Hz-150Hz \pm 3dB, -10dB @ 35Hz
DRIVER	12" (300mm)/3" (75mm) voice coil, long excursion, ferrite magnet, waterproof cone
RATED POWER (2)	400W AES, 1600W peak
RECOMMENDED AMPLIFIER	iK81 / VIA2502/5002/5004
SENSITIVITY (10)	100dB
MAXIMUM SPL (9)	126dB continuous, 132dB peak (half space)
NOMINAL IMPEDANCE	8 ohms
DISPERSION (-6dB)	Omnidirectional
CROSSOVER	80-120Hz active
ENCLOSURE	52 litres, Plywood
FINISH	Black or white textured paint
PROTECTIVE GRILLE	Black or white perforated steel
CONNECTORS	2 x NL4
PIN CONNECTIONS	Left to right: Input+, Input -, Link -, Link+
FITTINGS	12 x M10 inserts
DIMENSIONS	(W) 487mm x (H) 390mm x (D) 410mm (W) 19.2ins x (H) 15.4ins x (D) 16.1ins
WEIGHT	21.5kg (47.3lbs)

Notes

- (1) Measured on-axis in half (2pi) space at 2 metres, then referred to 1 metre.
- (2) AES Standard ANSI S4.26-1984.
- (3) Measured in half (2pi) space at 2 metres with 1 watt input, using band limited pink noise, then referred to 1 metre.
- (4) Measured in half (2pi) space at 2 metres using band limited pink noise, then referred to 1 metre.
- (5) Measured on-axis in open (4pi) space at 2 metres, then referred to 1 metre.
- (6) Measured in open (4pi) space at 2 metres with 1 watt input, using band limited pink noise, then referred to 1 metre.
- (7) Measured in open (4pi) space at 2 metres using band limited pink noise, then referred to 1 metre.
- (8) Measured in open (4pi) space at 2 metres with 2.83V input, using band limited pink noise, then referred to 1 metre.
- (9) Calculated at 1 metre.
- (10) Measured in half (2pi) space at 2 metres with 2.83V input, using band limited pink noise, then referred to 1 metre.

Trade Descriptions Act

Due to Martin Audio's policy of continuing improvement, we reserve the right to alter these specifications without prior notice. Martin Audio is committed to refining state of the art sound reinforcement, combining in-depth product and field applications research with advanced manufacturing techniques. Every Martin Audio product is built to the highest manufacturing standards and rigorously tested to ensure that it meets the performance criteria specified in the design.

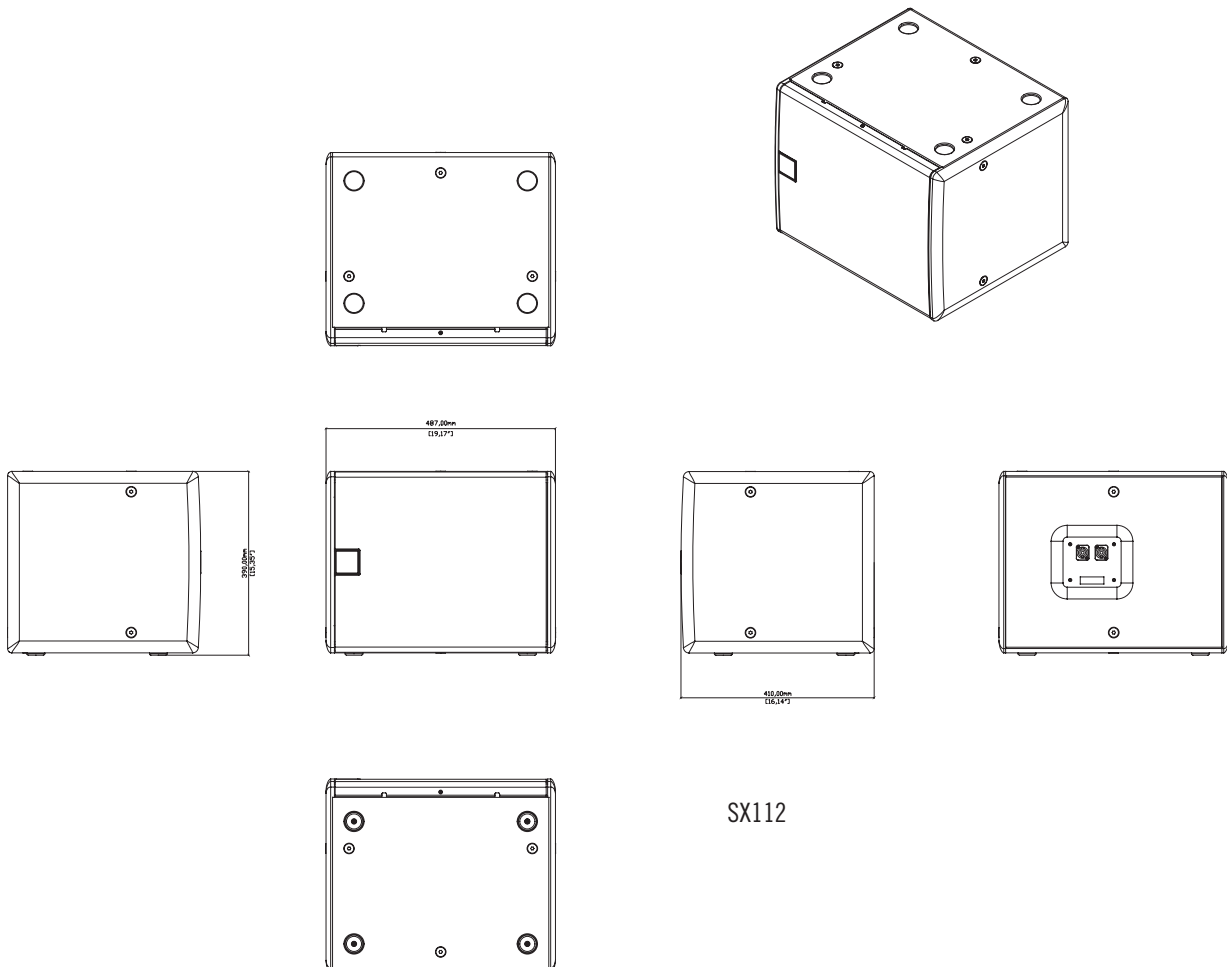

SX112